

J30102

SOLLEVATORE A 2 SFILATE

2-STAGE JACK - CRIC À 2 ÉTAGES - WAGENHEBER MIT 2 STUFEN - ELEVADOR DE DOS ETAPAS

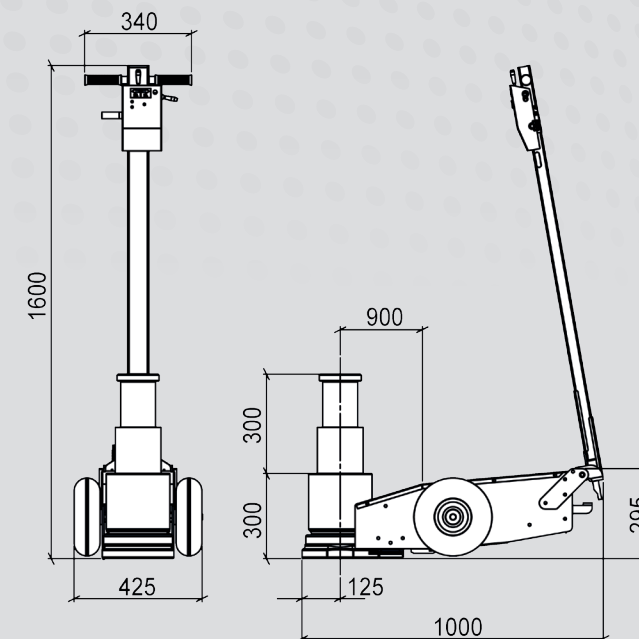
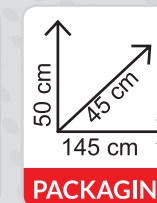

	SFILATA STAGE ÉTAGE STUFEN EXTRACCIÓN	PORTATA CAPACITY CAPACITÉ DE CHARGE TRAGFÄHIGKEIT CAPACIDAD	PRESIONE D'ESERCIZIO WORKING PRESSURE PRESSION DE SERVICE BETRIEBSDRUCK PRESIÓN DE SERVICIO	PROLUNGHE A RICHIESTA EXTENSIONS ON REQUEST RALLONGES SUR DEMANDE VERLÄNGERUNGEN AUF ANFRAGE ALARGADORES BAJO PEDIDO	PESO NETTO NET WEIGHT POIDS NET NETTOGEWICHT PESO NETO	
	J301302	Kg.	BAR	P.S.I.	h. mm.	Kg.
7.048.0762	1	100.000	10	143	PT 25-35 5.033.0941	155
	2	60.000			PTS46-5-35 7.078.0945 PL 58 H 5.066.0941 PL 108 H 5.066.0942	